

MULTIPLE UNIT

2 POSTS

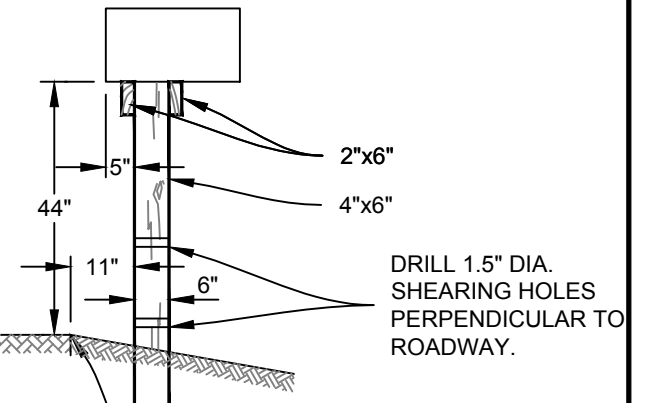
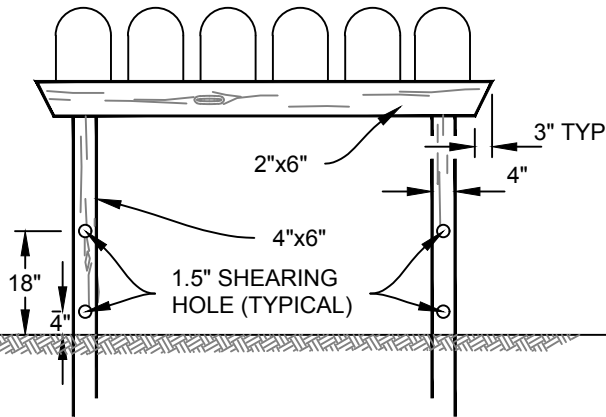

DRILL 1.5" DIA. SHEARING HOLES PERPENDICULAR TO ROADWAY.

EDGE OF PAVEMENT (OVERLAY) OR EDGE OF BASE ROCK SHOULDER (RECONSTRUCT OR CHIPSEAL)

NOTES:

1. ALL LUMBER SHALL BE PRESSURE TREATED DOUGLAS FIR, WESTERN HEMLOCK, OR WESTERN PINE.
2. ALL POSTS TO BE SET AT A MINIMUM OF 24" BELOW SURFACE OF GROUND.
3. TREAT CUT OR DRILLED PRESSURE TREATED LUMBER WITH JASCO TERMIN 8 GREEN PRESERVATIVE OR APPROVED EQUIVALENT.
4. REINSTALL NEWSPAPER BOXES ON NEW MAILBOX POST OR AS DIRECTED.



CALL 48 HOURS BEFORE YOU DIG

JACKSON COUNTY ROADS
MIKE KUNTZ, P.E. COUNTY ENGINEER

Date	By	Revision

JCRD201: MAILBOX STAND-MULTIPLE	
I:\Engineering\LIBRARY\COUNTY\STD_DWG\CURRENT\RD200-Mailbox\JCRD201-MailboxMult.dwg	
OCT 2017	NO SCALE

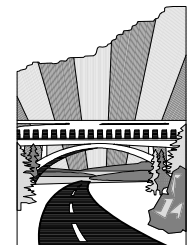

JACKSON
COUNTY

Roads